

6HA2M-WHT
M-rating 257kW [350mhp]
6HA2M-WDT
M-rating 298kW [405mhp]

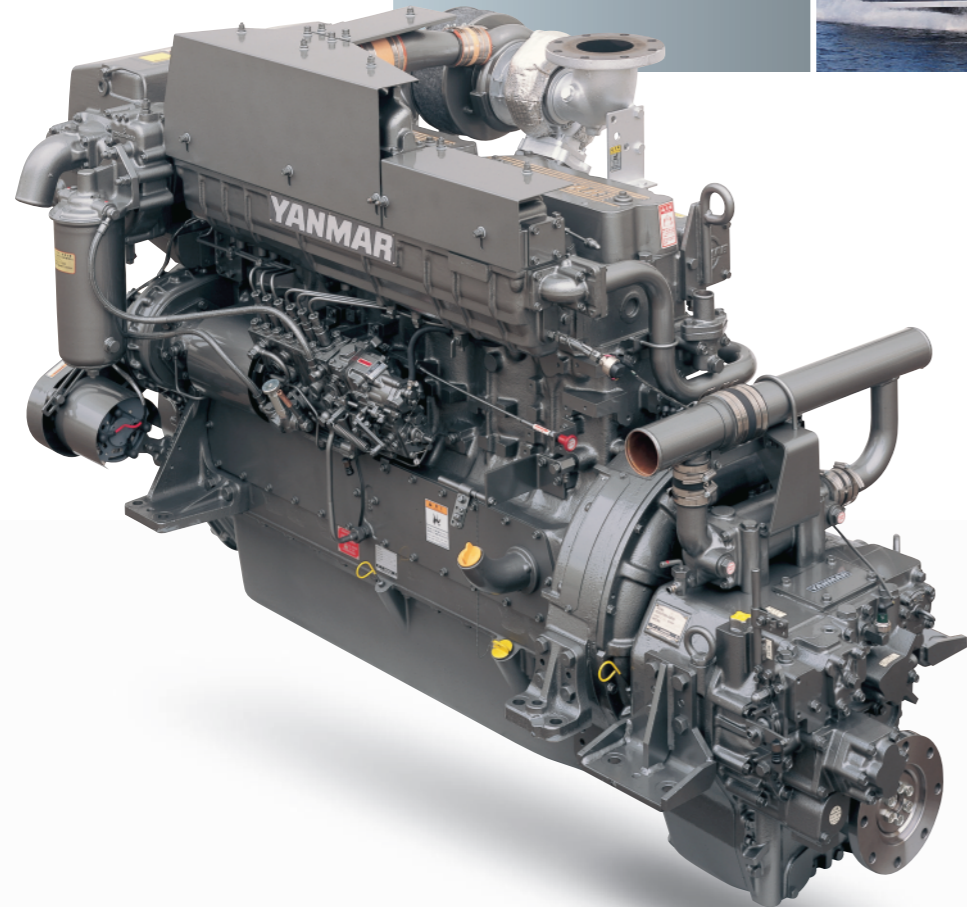

Reliability,
Efficiency, Innovation
for Customers
Dedicated to
Maritime Activities.



Photograph may show optional equipment.

Engine Specifications

Model	6HA2M-WHT		6HA2M-WDT
Type	4-cycle, Vertical, Turbo-charged diesel engine		
No. of cylinders	6 in-line		
Bore × stroke	mm 130 × 165		
Displacement	lit. 13.140		
Rated output	kW(hp) / rpm	M:257(350) / 1950	H:204 (278) / 1880
Fuel consumption	gr/kW·hr	M:217(at rated output)	H:217(at rated output)
Direction of rotation	Counterclockwise viewed from stern (crankshaft)		
Combustion system	Direct injection		
Cooling system	Fresh water cooling with sea water & Fresh water pumps		
Lubricating system	Forced lubrication with gear pump		
Starting system	Electric starting motor (DC 24V)		
Dry weight	kg	1455	1465

Marine Gear Specifications

Engine Model	6HA2M-WHT				6HA2M-WDT								
Marine gear model	YX-120				YX-120L								
Type	Hydraulic multi-disc clutch												
Reduction ratio	2.03	2.57	3.04	3.55	4.00	4.59	2.03	2.57	3.04	3.46	4.00	4.59	
Prop. shaft speed at rated output	rpm	961	759	641	549	488	425	961	759	641	564	488	425
Direction of rotation	Clockwise or Counterclockwise												
Dry weight	kg	310		385		310		385					

Dimensions (Unit : mm)

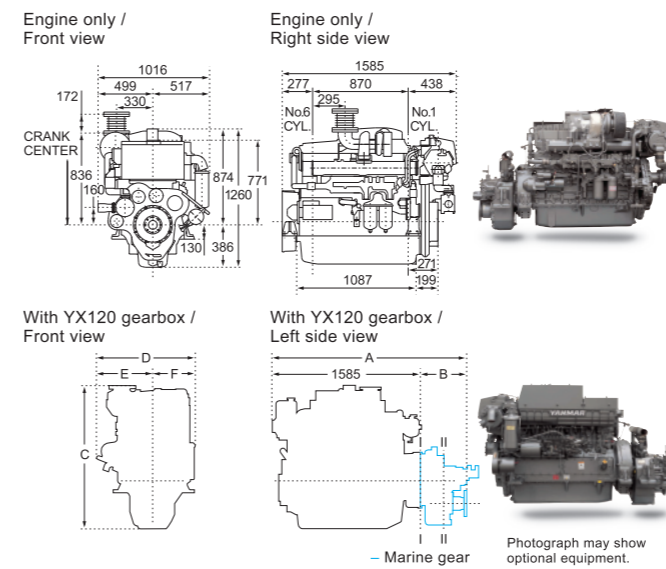

Model	A	B	C	D	E	F
6HA2M-WHT × YX-120	2005	420	1272	1016	499	517
6HA2M-WHT × YX-120L	2039	454	1384	1016	499	517
6HA2M-WDT × YX-120	2005	420	1272	1036	519	517
6HA2M-WDT × YX-120L	2039	454	1384	1036	519	517

Performance Curves

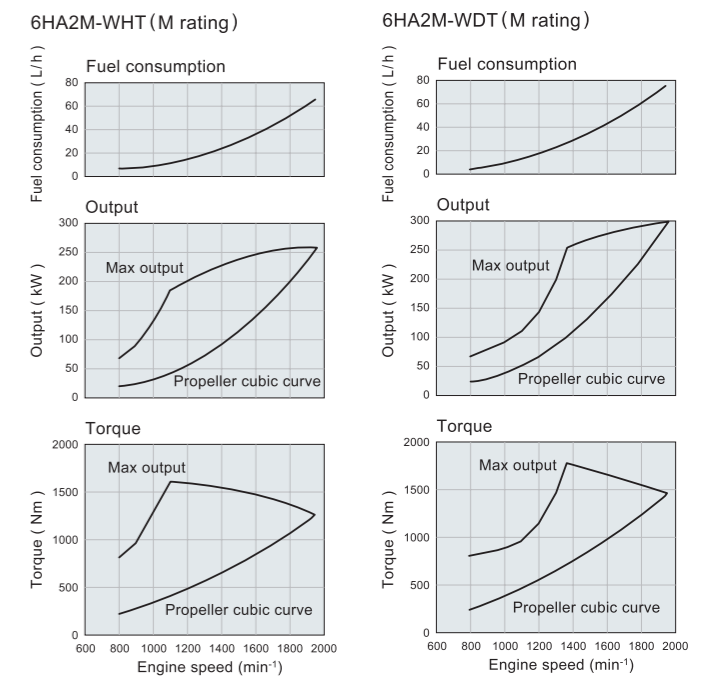

YANMAR CO., LTD.

Marine Operations Division.
5-3-1, Tsukaguchi Honmachi Amagasaki, Hyogo, Japan
Tel : +81-6-6428-3120 Fax : +81-6-6421-2202
www.yanmar.co.jp/en

Note : All Data Subject to Change Without Notice.

For Harmonious Living with Global Environment

YANMAR ECOLOGY

lower fuel consumption and lower NOx emissions **At the Same Time**

IMO Tier II Compliant

Lower fuel consumption
Lower NOx emissions

Doing Our Bit for the World!

Normally, when NOx emissions are reduced, the fuel consumption and smoke generation will increase, adversely affecting both the environment and management. As a solution to this, YANMAR has developed "Eco Diesel", which is designed so as to comply with marine environmental protection. It improves the fuel consumption and smoke generation in addition to reducing NOx emissions.



Powerful and Friendly to People and Environment!

Performance

405hp (298kW) at 1950rpm

This 165 mm long stroker 13 liter class diesel, with big breathing valves for better airflow, the high performance turbo for, less turbo lag, and better mixing at low revs, the all-new high efficiency intercooler for cooler, more compact air charging, and the numerous other performance features deliver power in large amounts over a wide operating range, especially under high load conditions.

Good Fuel Economy together with Lower Emissions

The micro-sized multiple holes in the all-new injectors produce an even finer fuel-oil mist and, combined with new perfectly matched combustion chambers and new cylinder head shapes, produce even more power. It is power delivered smoothly, due to optimum combustion conditions being maintained across a far wider operating range. And it leads directly to the bonus of lower exhaust emissions and lower fuel consumption. The boost compensator dramatically reduces black smoke under hard acceleration.

High Torque

Excellent Torque-Rise Characteristics in High Speed and High Load Range Enable Stable Performance of Job Duties even at High Load

The Engine Performance Gives Following Advantages:

1. The engine torque-rise characteristics having much in reserve, (Line A)
→ Stable cruising with least speed reduction against sudden load changes.
2. Wide Max. Power Range, (Line B)
→ A wide range propeller matching, from the passenger ship (light/medium duty) to tug boat (heavy duty), is possible.
3. Min. Fuel Consumption Range is Wide, (Line C)
→ Economical with wide min. fuel consumption range both during cruising or performing job duties.
4. Wide Medium Load Range, (Line D)
→ Produces stable engine performance even doing other job duties.

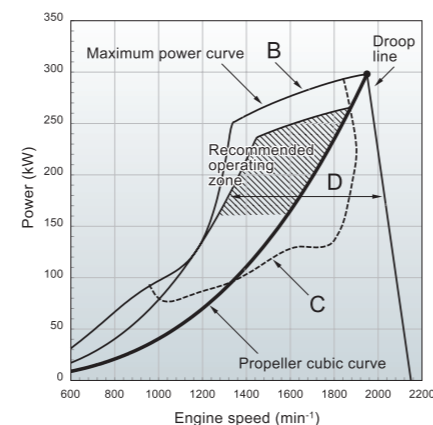
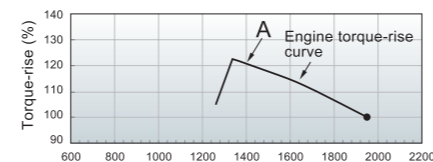

This figure indicate in case of 6HA2M-WDT (M-rating)

Toughness

1. Designed for marine use.
2. Type Approved by Class Societies.
3. Low, stable LOC (Lubricating Oil Consumption) and long overhaul interval.
4. Tufftride treatment cylinder liner and nitrided stainless steel rings and the finely judged clearance between piston and liner.
5. Special treatment injection nozzle.

Safety

Easier Routine Inspection, Easier Maintenance.

Large inspection windows on the side of the block allow in-site replacement of pistons. Lube Oil filter is easy-to-replace cartridge type. Full mechanical engine management avoids the chance of delicate and expensive electronics failing in hot, marine engine room conditions. Maintenance is simplified, inspection and replacement costs are lower. Reliability and durability are enhanced. Engine is user-friendly.

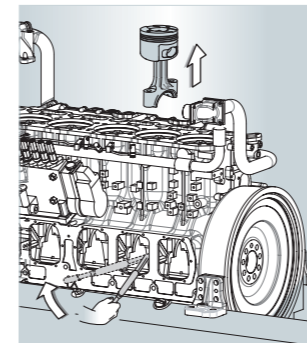

High capacity front PTO

If makes various applications possible. for your professional activities on the sea.

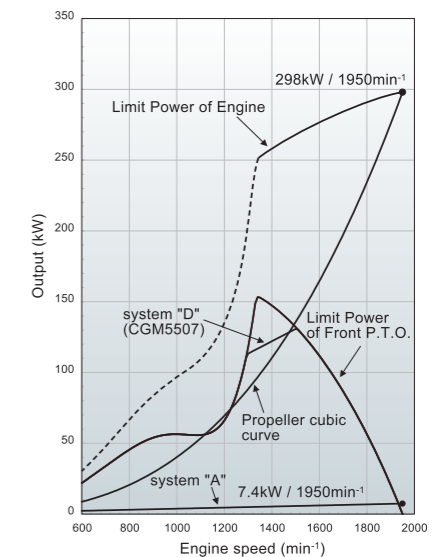

YANMAR original marine gear that can be adapted to a wide range of applications

YANMAR provides our original gearbox, which enables us to supply total marine engineering & servicing to customers!

High-Performance Marine Gear

YANMAR's original marine gear is designed to draw out best performance of YANMAR engines.

Easier Maintenance

The 3-part structure of the case enables the forward shaft and reverse shaft to be disassembled and reassembled while still installed on the boat. In addition, a cartridge system is now used for the L.O. filter.

Large Capacity & Long Service Life

A fiber friction plate delivers improved trolling performance and increased clutch capacity. In addition, a finer LO filter extends the service life of the bearings and moving parts.

Damping of Fluctuating Torque

High-performance coupling reduces the fluctuating torque that is input to the marine gear. They reduce rattling and prevent torsional vibration to protect the power transmission parts.

