

CARDAN LENGTH	D	E	F
STD 370 ±5mm	816 ±15	895 ±15	3281 ±15
700-800mm	1146-1246	1225-1325	3617-3717
1100-1200mm	1546-1646	1625-1725	4017-4117
1500-1600mm	1946-2046	2025-2125	4417-4517
1900-2000mm	2346-2446	2425-2525	4817-4917
2300-2500mm	2846-2946	2925-3025	5317-5417

A*	B	C
5	739	674
6	747	659
7	756	644
8	765	628
9	774	611
10	784	594
11	794	577
12	804	559
13	814	540
14	825	521
15	836	501
16	847	481
17	859	459
18	871	438
19	883	415
20	896	392
21	909	369
22	923	344
23	937	319
24	951	293

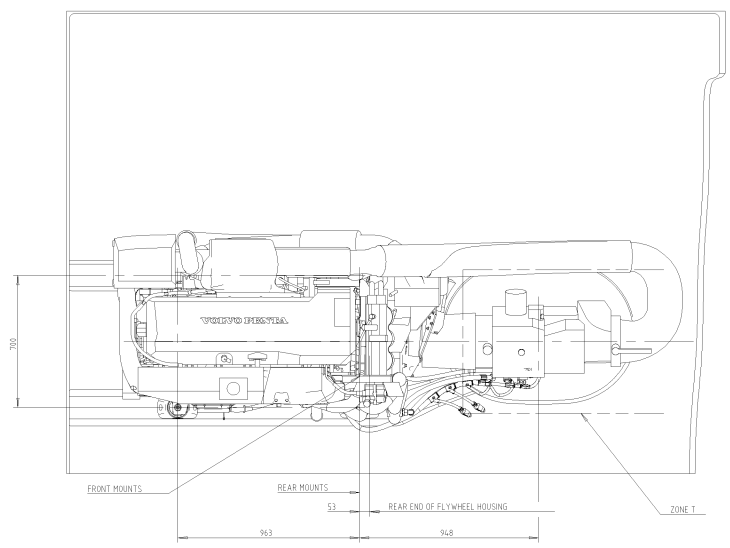
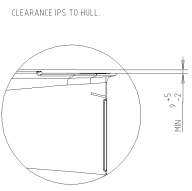

IPS UNIT

- (L) CONNECTION WATER IN OIL
- (K) OIL DRAIN (2x)
- (J) CONNECTION RPM SENDER
- (H) CONNECTION ELECTRICAL CONTROL
- (G) CONNECTION BATTERY POS. AND NEG.
- (F) CONNECTION OIL TEMP./PRESSURE
- (E) CONNECTION SHIFT SOLENOIDES
- (D) OIL DIPSTICK GEAR BOX
- (C) OIL FILLER GEAR BOX

FOR EASY INSTALLATION, USE ENGINE/IPS BED INSTALLATION TOOL

ENGINE

SEE DIMENSION DRAWING FOR ENGINE

SCALE 1:10

<p>The owner, distributor and customer of the product shall be responsible for the correct use of the product. The manufacturer is not responsible for any damage caused by the use of the product in a way not intended by the manufacturer.</p>	<p>SYMBOLS, DIMENSIONS, TOLERANCES AND UNITS SHALL BE AS SHOWN UNLESS OTHERWISE SPECIFIED</p>	
	<p>Author: IPS</p> <p>Dimension Drawing: IPS 2D WITH DIT</p> <p>Revision: 1</p> <p>Dimension Drawing: IPS</p> <p>Part Identification Code: 22202230</p>	
<p>VOLVO PENTA</p>		<p>Scale: 1:10</p>