



8LV-320Z/350Z/370Z Series

Configuration	4-stroke, water-cooled diesel engine	
Maximum output at crankshaft according ISO 8665: 2006	*235 kW@3800 rpm *257 kW@3800 rpm *272 kW@3800 rpm	[320 mhp@3800 rpm] [350 mhp@3800 rpm] [370 mhp@3800 rpm]
Displacement	4.460 L	[272.24 cu in]
Bore x stroke	86 mm x 96 mm	[3.38 in x 3.78 in]
Cylinders	8 in V-90°	
Combustion system	Direct injection common-rail system	
Aspiration	Turbocharged with twin TC	
Alternator	12V - 180A	
Start-assist	Glow-plug system	
Cooling system	Fresh water cooling by centrifugal fresh water pump Sea water cooling by rubber impeller seawater pump	
Lubrication system	Enclosed, forced lubricating system	
Direction of rotation [crankshaft]	Counterclockwise viewed from stern	
Dry weight without gear	435 kg	[959 lbs]
Environmental	EU: RCD 2 US: EPA Tier3	EMC IMO
Engine mounting	Rubber type flexible mounting	

NOTE:Fuel condition: Density at 15°C = 0.84 g/cm³

* Fuel temperature 40°C at the inlet of the fuel injection pump [ISO 8665: 2006]

Technical data is according to ISO 8665: 2006/3046-1

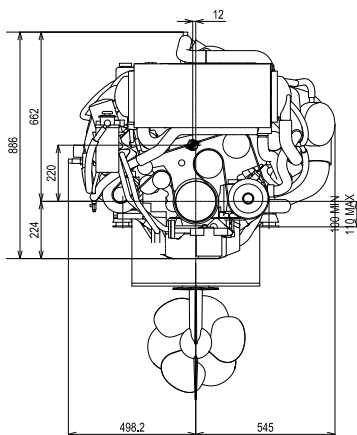
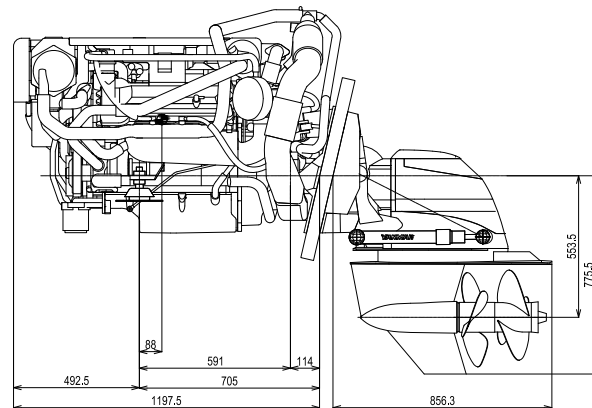
DIMENSIONS**Front view****Right side view**

8LV-320Z/8LV-370Z/8LV-370Z



PERFORMANCE CURVES

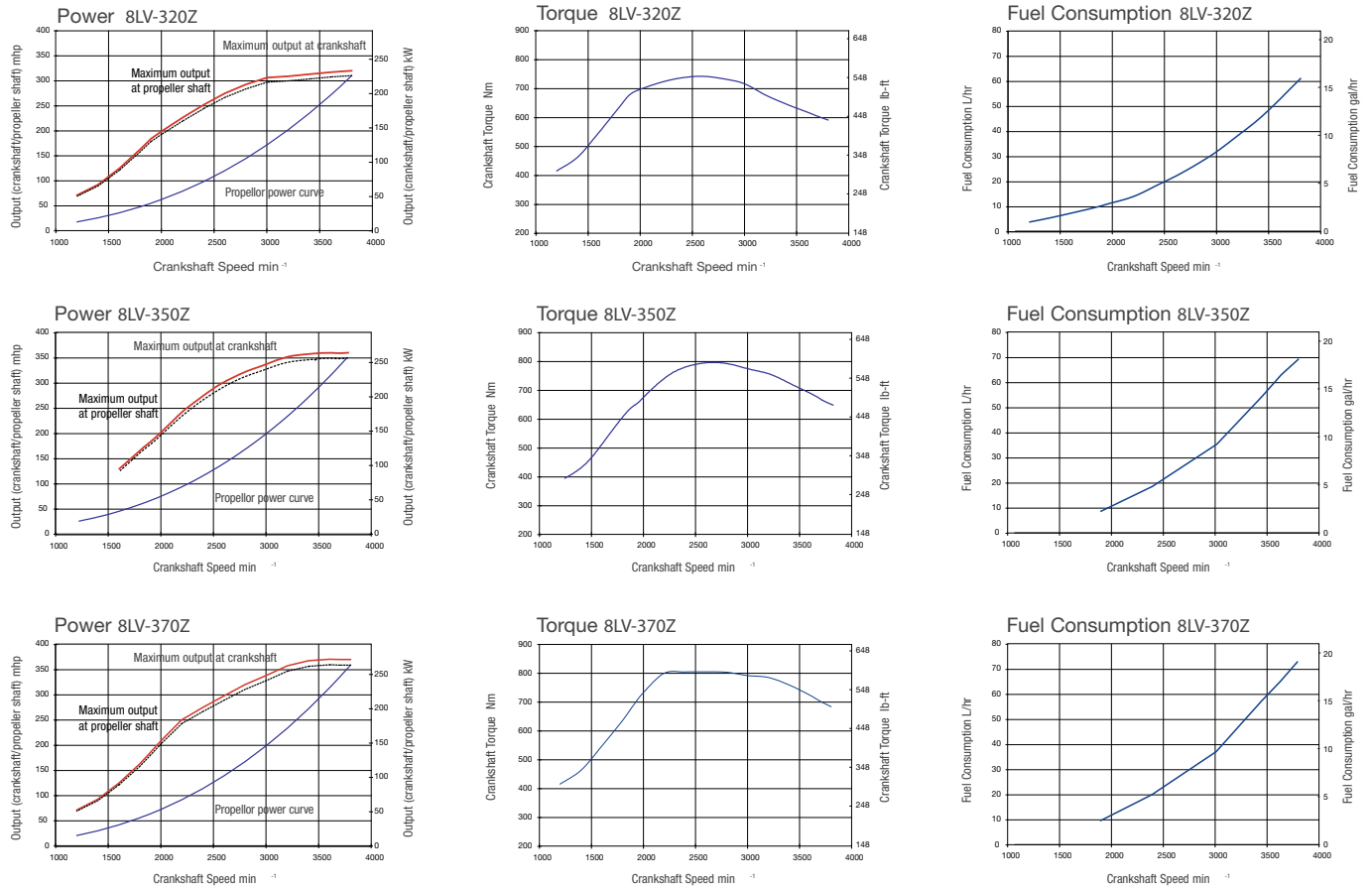

MARINE GEARS / DRIVE

Model	ZT370 [Steerable Z-drive with dual prop]	
Type	Hydraulic actuated multi-friction disc clutch	
Dry weight with propellers	112 kg [247 lbs]	
Reduction ratio [fwd/rev]	1.65/1.65	1.78/1.78
Propellor speed	2424/2424	2247/2247
Direction of rotation viewed from the stern	Clockwise [rear prop] & Counterclockwise [front prop]	
Lub oil specifications	Quick Silver HPGL	
Dry weight engine with sterndrive	547 kg [1205 lbs]	
Shift control	Mechanical or electro-magnetic	
Trim range	-6° - +10°	
Trailer limit	51°	

CONTROL SYSTEM

- YANMAR VC10 control system
- Electronic CAN-bus control-head
- Multi-function color display
- NMEA2000 or J1939 gauge output
- Second or third station - optional

OPTIONAL ACCESSORIES

- High-riser mixing elbow
- SOLAS kit
- Front-PTO pulley [V-belt type A or B]
- Hot water connector

NOTE: All data subject to change without notice. Text and illustrations are not binding.